

1/2" • 1"

CLASSIC PERFORMANCE

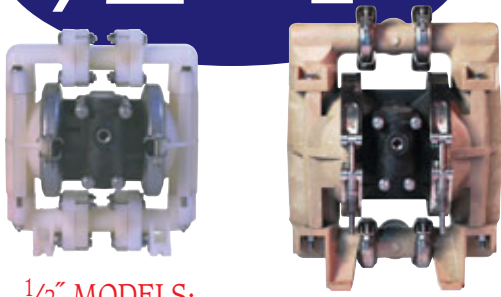

1/2" MODELS:

- NC-5** (Polypropylene/Geolast®) 8 lbs. (3,6 kg.)
- BK-5** (Polypropylene/PTFE) 8 lbs. (3,6 kg.)
- BK-5E** (Polypropylene/Santoprene®) 8 lbs. (3,6 kg.)
- KN-5** (PVDF/PTFE) 11 lbs. (4,9 kg.)
- KN-5E** (PVDF/Santoprene®) 11 lbs. (4,9 kg.)

1" MODELS:

- NC-10** (Polypropylene/Geolast®) 19 lbs. (8,6 kg.)
- BK-10** (Polypropylene/PTFE) 19 lbs. (8,6 kg.)
- BK-10E** (Polypropylene/Santoprene®) 19 lbs. (8,6 kg.)
- KN-10** (PVDF/PTFE) 22 lbs. (9,9 kg.)
- KN-10E** (PVDF/Santoprene®) 22 lbs. (9,9 kg.)

See page 4 for fastener and valve seat material.

SPECIFICATIONS:

Maximum Temperature:

- KN Models 200°F (93°C)
- Other Models 150°F (66°C)

Maximum Air Pressure: 100 PSI (6,8 bar)

Minimum Air Pressure: 20 PSI (1,3 bar)

Dry Lift:

- Models w/PTFE balls 10 ft. (3 meters)
- Other Models 15 ft. (4,5 meters)

SPECIFICATIONS (1/2" MODELS):

Capacity:

Adjustable 0 to 14 GPM (53,2 liters/min.)

Maximum Solids: 1/8" (3,2 mm)

Air Supply:

- Inlet 1/4" NPT Female
- Outlet 3/8" NPT Female
- Muffler supplied

Fluid Inlet/Discharge:

- All Models 1/2" NPS Female (BSP or NPT Compatible)
- For optional dual manifold inlet/outlet, add -P25 to Model No.

SPECIFICATIONS (1" MODELS):

Capacity:

Adjustable 0 to 40 GPM (152 liters/min.)

Maximum Solids: 1/4" (6,4 mm)

Air Supply:

- Inlet 1/4" NPT Female
- Outlet 3/8" NPT Female
- Muffler supplied

Fluid Inlet/Discharge: 1" NPT

- For optional BSP threads, add -P15 to Model No.

PLASTIC Dimensions in inches and (mm). Ports shown facing front for dimensional purposes.

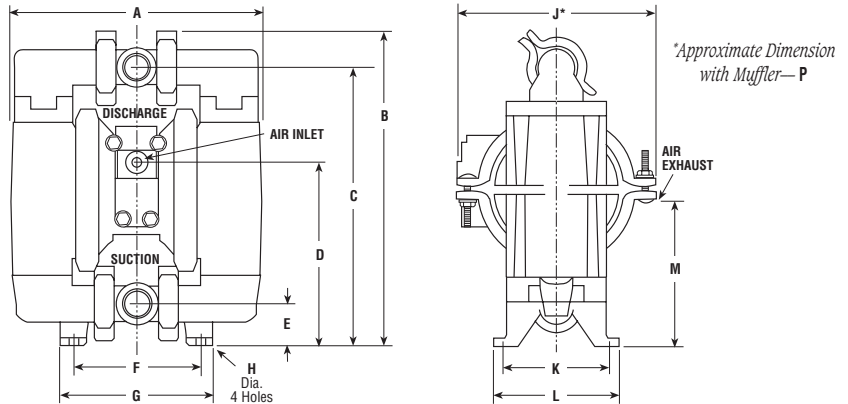

MODEL	DIMENSIONS Inches / (mm)												
SIZE	A	B	C	D	E	F	G	H	J	K	L	M	P
1/2" Models	9.76 (248,0)	10.75 (273,0)	9.38 (238,0)	6.19 (157,2)	1.38 (35,0)	5.70 (145,0)	6.70 (170,0)	0.31 (8,0)	7.50 (190,5)	3.26 (83,0)	4.00 (102,0)	5.12 (130,0)	8.00 (203,2)
1" Models	12.00 (305,0)	15.50 (394,0)	13.50 (343,0)	8.30 (211,0)	2.00 (51,0)	5.74 (146,0)	7.62 (194,0)	0.44 (11,2)	9.90 (252,0)	5.12 (130,0)	6.00 (152,4)	8.30 (211,0)	11.57 (293,9)

PERFORMANCE CURVE (1/2" MODELS)

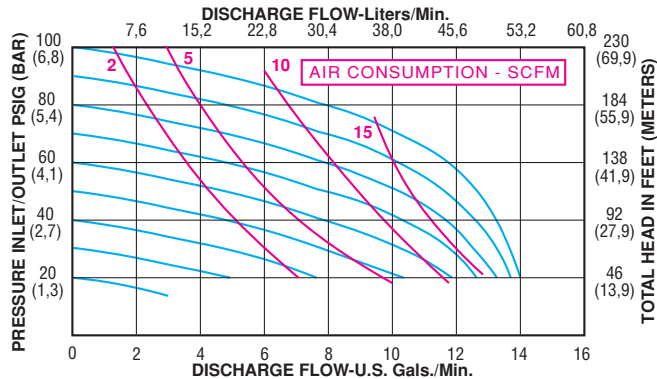

PERFORMANCE CURVE (1" MODELS)

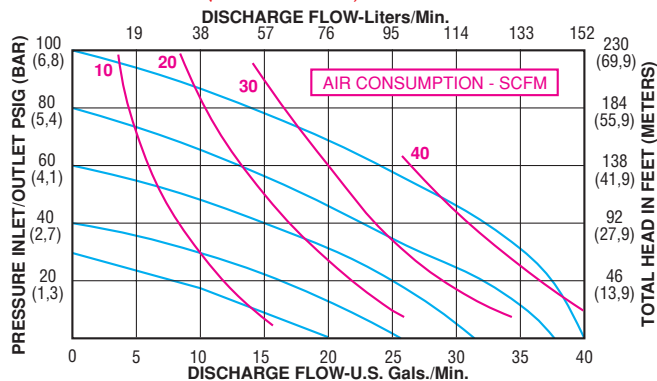

Dual Manifold/Split Delivery

1. The pump can be used as two pumps in one, isolating two different fluids or recycling on one side and using the opposite side for delivery.
 2. A dual manifold used only on the suction side of the pump can be used to mix two different fluid that must be kept separate prior to transfer such as a two part epoxy.
 3. A dual manifold used only on the discharge side of the pump will split the delivery.
- Add -P25 after the model number to have the pump configured at the factory with dual manifolds.
 - Fluid must be transferred through both sides of the pump.